

Name	FUNNEL SUSPENSION CI																																																				
Reference	FUNNEL SUSPENSION 150 CI																																																				
	479726	FUNNEL SUSPENSION 150 CI 2700K TEXT BLACK																																																			
	479736	FUNNEL SUSPENSION 150 CI 3000K TEXT BLACK																																																			
	479746	FUNNEL SUSPENSION 150 CI 4000K TEXT BLACK																																																			
	479747	FUNNEL SUSPENSION 150 CI 2700K TEXT WHITE																																																			
	479757	FUNNEL SUSPENSION 150 CI 3000K TEXT WHITE																																																			
	479767	FUNNEL SUSPENSION 150 CI 4000K TEXT WHITE																																																			
	479786	FUNNEL SUSPENSION 150 CI 2700K TEXT BLACK + GOLD																																																			
	479796	FUNNEL SUSPENSION 150 CI 3000K TEXT BLACK + GOLD																																																			
	479776	FUNNEL SUSPENSION 150 CI 4000K TEXT BLACK + GOLD																																																			
	479782	FUNNEL SUSPENSION 150 CI 2700K TEXT WHITE + GOLD																																																			
	479792	FUNNEL SUSPENSION 150 CI 3000K TEXT WHITE + GOLD																																																			
	479772	FUNNEL SUSPENSION 150 CI 4000K TEXT WHITE + GOLD																																																			
		FUNNEL SUSPENSION 240 CI																																																			
		479826	FUNNEL SUSPENSION 240 CI 2700K TEXT BLACK																																																		
479836		FUNNEL SUSPENSION 240 CI 3000K TEXT BLACK																																																			
479846		FUNNEL SUSPENSION 240 CI 4000K TEXT BLACK																																																			
479847		FUNNEL SUSPENSION 240 CI 2700K TEXT WHITE																																																			
479857		FUNNEL SUSPENSION 240 CI 3000K TEXT WHITE																																																			
479867		FUNNEL SUSPENSION 240 CI 4000K TEXT WHITE																																																			
479886		FUNNEL SUSPENSION 240 CI 2700K TEXT BLACK + GOLD																																																			
479896		FUNNEL SUSPENSION 240 CI 3000K TEXT BLACK + GOLD																																																			
479876		FUNNEL SUSPENSION 240 CI 4000K TEXT BLACK + GOLD																																																			
479882		FUNNEL SUSPENSION 240 CI 2700K TEXT WHITE + GOLD																																																			
479892	FUNNEL SUSPENSION 240 CI 3000K TEXT WHITE + GOLD																																																				
479872	FUNNEL SUSPENSION 240 CI 4000K TEXT WHITE + GOLD																																																				
Specifications	<table border="1"> <tr> <td>Safe distance to object</td> <td colspan="2">☰ - 0,1m - ☷</td> </tr> <tr> <td>Lamp type</td> <td colspan="2">LUXEON M</td> </tr> <tr> <td>CCT</td> <td colspan="2">2700K / 3000K / 4000K</td> </tr> <tr> <td>Luminous flux</td> <td colspan="2">2700K: 755lm / 3000K: 810lm / 4000K: 905lm</td> </tr> <tr> <td>Power</td> <td colspan="2">7,84 W</td> </tr> <tr> <td>Current</td> <td colspan="2"></td> </tr> <tr> <td>Voltage</td> <td colspan="2">230V 50-60Hz AC</td> </tr> <tr> <td>Symbol</td> <td colspan="2">⚡</td> </tr> <tr> <td>Gear</td> <td colspan="2">Converter incorporated</td> </tr> <tr> <td>IP / Class</td> <td colspan="2">IP20</td> </tr> <tr> <td>Application</td> <td colspan="2">Ceiling suspended</td> </tr> <tr> <td>Orientability</td> <td colspan="2">None</td> </tr> <tr> <td>Dimmability</td> <td colspan="2">mains dimmable RC (via dimlist type O)</td> </tr> <tr> <td>Beamangle</td> <td colspan="2">36°</td> </tr> <tr> <td>CRI</td> <td colspan="2">90</td> </tr> <tr> <td>SDCM</td> <td colspan="2">3</td> </tr> <tr> <td>Weight</td> <td colspan="2">See above</td> </tr> </table>		Safe distance to object	☰ - 0,1m - ☷		Lamp type	LUXEON M		CCT	2700K / 3000K / 4000K		Luminous flux	2700K: 755lm / 3000K: 810lm / 4000K: 905lm		Power	7,84 W		Current			Voltage	230V 50-60Hz AC		Symbol	⚡		Gear	Converter incorporated		IP / Class	IP20		Application	Ceiling suspended		Orientability	None		Dimmability	mains dimmable RC (via dimlist type O)		Beamangle	36°		CRI	90		SDCM	3		Weight	See above	
Safe distance to object	☰ - 0,1m - ☷																																																				
Lamp type	LUXEON M																																																				
CCT	2700K / 3000K / 4000K																																																				
Luminous flux	2700K: 755lm / 3000K: 810lm / 4000K: 905lm																																																				
Power	7,84 W																																																				
Current																																																					
Voltage	230V 50-60Hz AC																																																				
Symbol	⚡																																																				
Gear	Converter incorporated																																																				
IP / Class	IP20																																																				
Application	Ceiling suspended																																																				
Orientability	None																																																				
Dimmability	mains dimmable RC (via dimlist type O)																																																				
Beamangle	36°																																																				
CRI	90																																																				
SDCM	3																																																				
Weight	See above																																																				



NL Installatie- en onderhoudsrichtlijnen m.b.t. de fabrieksgarantie.
 1. De plaatsing, de aansluiting en het uittesten van dit toestel dient steeds te gebeuren door een erkend elektro-installeator.
 2. Dit toestel moet geïnstalleerd, verbonden en getest worden volgens de nationaal geldende reglementen op elektrische installaties.
 3. De technische bijsluiter dient te worden beschouwd als een onderdeel van de algemene verkoopvoorwaarden van TAL nv.
 4. De elektro-installeator is verantwoordelijk voor het gebruik van compatibele voorschakelapparatuur die voldoen aan de geldende IEC normen.
 5. Reinig het toestel enkel met een zachte en lichtvochtige doek zonder reinigingsmiddel.
 6. Schakel altijd eerst de elektriciteit uit alvorens het toestel te plaatsen en te installeren.

EN Installation and maintenance instructions regarding the manufacturer's warranty.
 1. Installation, connection and testing of this product must always be performed by a certified electrician.
 2. This product must be installed, connected and tested in accordance with the applicable national regulations for electrical installations.
 3. The technical manual must be regarded as part of the general sales conditions of TAL nv.
 4. The electrical installer is responsible for the use of compatible control gear that meets the applicable IEC standards.
 5. Only clean the device with a soft and slightly moist cloth without detergent.
 6. Always switch off the electricity supply before installing and connecting the product.

DE Installations- und Wartungsanweisungen bezüglich der Herstellergarantie.
 1. Installation, Anschluß und Prüfung dieses Geräts soll nur von einem anerkannten Elektriker ausgeführt werden.
 2. Dieses Gerät soll in Übereinstimmung mit den nationalen geltenden Vorschriften für Elektroinstallationen installiert, angeschlossen und geprüft werden.
 3. Die technische Anleitung muß als Teil der allgemeinen Verkaufsbedingungen von TAL nv betrachtet werden.
 4. Der Elektroinstallateur ist verantwortlich für die Verwendung von kompatiblen Betriebsgeräten, die den geltenden IEC-Normen entsprechen.
 5. Reinigen Sie das Gerät nur mit einem weichen und leicht feuchten Tuch ohne Reinigungsmittel.
 6. Schalten Sie den Strom immer aus, bevor Sie das Gerät installieren und anschließen.

FR Instructions d'installation et d'entretien concernant la garantie du fabricant.
 1. L'installation, la connexion et les essais de cet appareil doivent toujours être effectués par un électricien reconnu.
 2. Cet appareil doit être installé, raccordé et testé conformément aux réglementations nationales pour les installations électriques.
 3. La notice technique doit être considérée comme faisant partie des conditions générales de vente de TAL SA.
 4. L'installateur électrique est responsable de l'utilisation d'un équipement de contrôle compatible qui satisfait aux normes CEI applicables.
 5. Nettoyez l'appareil uniquement avec un chiffon doux et légèrement humide sans détergent.
 6. Éteignez toujours l'électricité avant d'installer et de connecter l'appareil.

Installation

1 Make drillpattern on ceiling

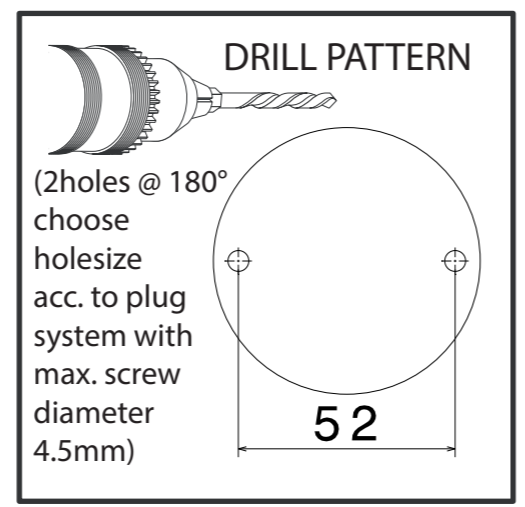

2 Adjust cable length & make electrical connection

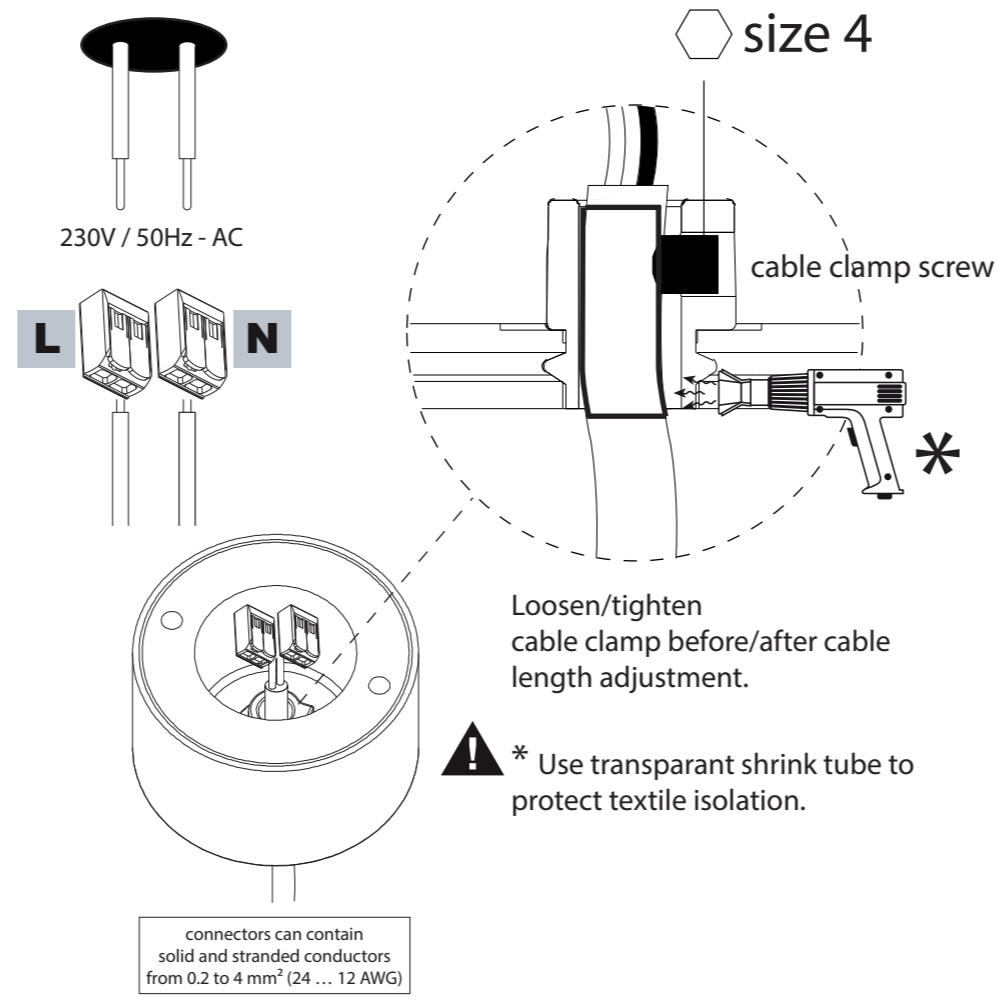

3 Mount the ceiling bracket (see drill pattern)

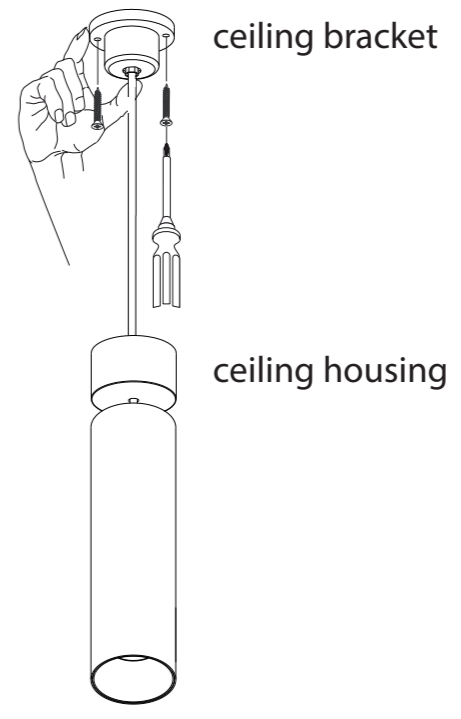

4 Fix the ceiling housing

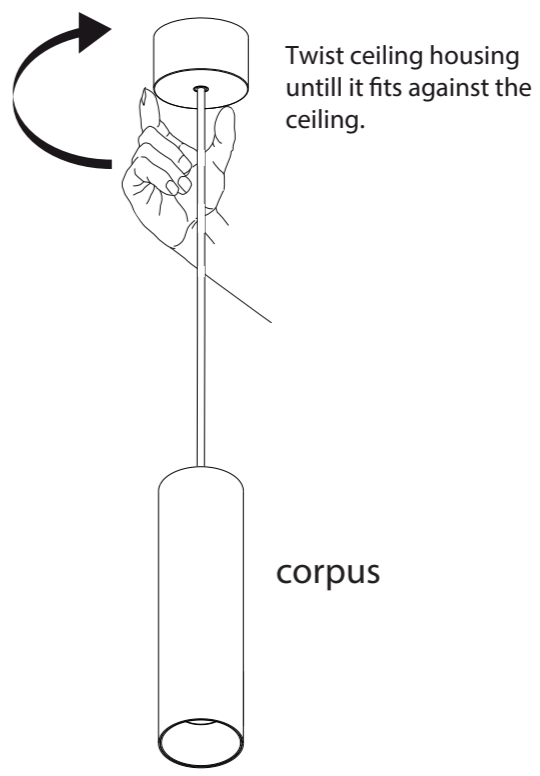

5 Switch on mains power supply

! ALWAYS DISCONNECT MAINS POWER SUPPLY FROM CONVERTER BEFORE SWITCHING "ON" LED LUMINAIRES TO PREVENT HOT PLUGGING ISSUES